

Fittings

Suction fittings

for series F1, F2 and T1 pumps

A 'suction fitting' consists of a straight, 45°, 90° or 135° suction fitting, 2 clamps, 2 cap screws and an O-ring.

'Straight' suction fittings

Ordering no.	A mm	B mm	C dia. mm (in.)
378 0635	0	85	38 (1½")
378 0636	17	136	50 (2")
378 0637	25	145	63 (2½")
378 0973	17	136	45
378 0974	17	136	48

45° suction fittings

Ordering no.	A mm	B mm	C dia. mm (in.)
378 1234 ¹⁾	60	104	32 (1¼")
378 0633 ¹⁾	60	104	38 (1½")
378 0364 ²⁾	67	110	50 (2")
378 0634	75	117	63 (2½")
378 1062	67	110	40
378 0975	67	110	45
378 0965	67	110	48

- 1) Suitable for frame size F1-25.
- 2) Suitable for pump sizes F1-41,-51,-61,-81 and -110.

90° suction fittings

Ordering no.	A mm	B mm	C dia. mm (in.)
378 0978	126	83	38 (1½")
378 0979	135	83	50 (2")
378 0976	135	83	45
378 0977	135	83	48
378 1980	147	103	63 (2½")

135° suction fitting

Ordering no.	A mm	B mm	C dia. mm (in.)
378 1867	166	73	50 (2")

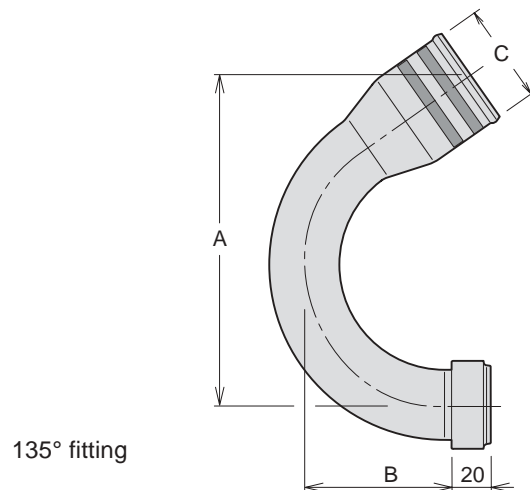
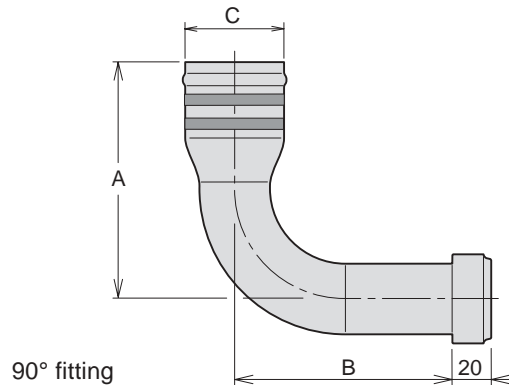
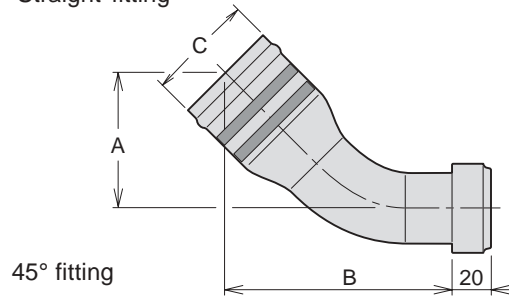
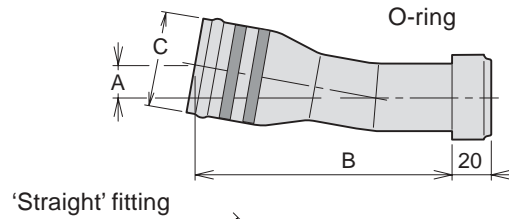
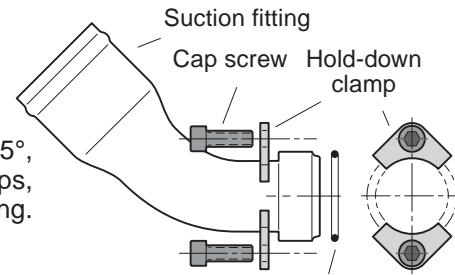

8

9

NOTE: A suction fitting *must be ordered separately* (not included with the pump).

Fitting kits

for series F1 and VP1 pumps

Kits with straight suction fitting

Pump size	Ordering no.	C ₁	C ₂ dia.
F1-20/-30	370 4934	BSP 1/2"	1 1/2"
F1-40/-60	370 4935	BSP 3/4"	2"
F1-80/-110; VP1	370 4936	BSP 3/4"	2"
F1-80/-110; VP1*	370 7220	BSP 1"	2"

* Above 100 l/min

Pressure fitting

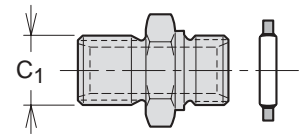

Straight suction fitting

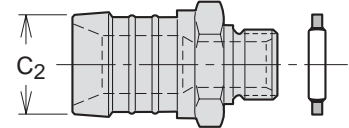

Kits with 45° suction fitting

Pump size	Ordering no.	C ₁	C ₂ dia.
F1-20/-30	370 9017	BSP 1/2"	2"
F1-40/-60	379 9564	BSP 3/4"	2"
F1-80/-110; VP1	379 9563	BSP 3/4"	2"
F1-80/-110; VP1*	379 9562	BSP 1"	2 1/2"

Pump size	A	B
F1-20/-30	71	154
F1-40/-60	"	"
F1-80/-110; VP1	"	"
F1-80/-110; VP1*	64	147

* Above 100 l/min

Pressure fitting

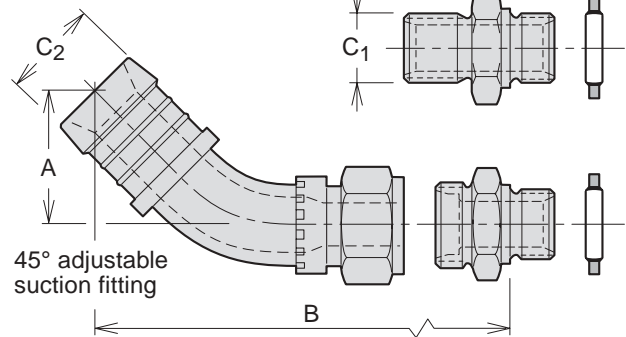
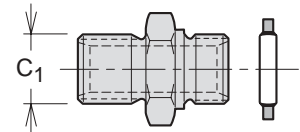

Kits with 90° suction fitting

Pump size	Ordering no.	C ₁	C ₂ dia.
F1-20/-30	379 9915	BSP 1/2"	2"
F1-40/-60	379 9916	BSP 3/4"	2"
F1-80/-110; VP1	379 9918	BSP 1"	2"

Pump size	A	B
F1-20/-30	144	128
F1-40/-60	"	"
F1-80/-110; VP1	"	"

Pressure fitting

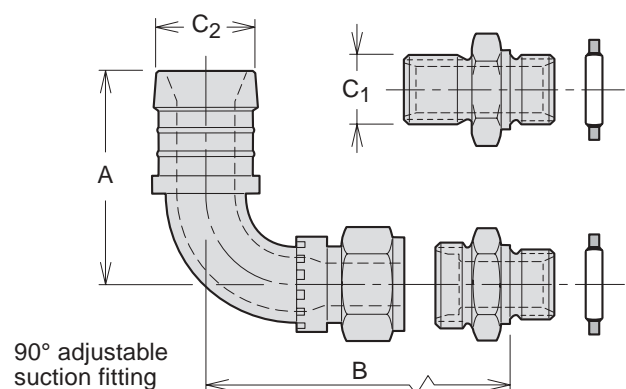
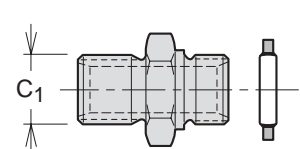

NOTE: Each kit consists of a pressure fitting, a suction fitting, and corresponding seal washers.